

SAFETY TOP CAP™

Safety Top Cap™ serves two purposes; first, the unique design provides protection against bodily injury by covering the exposed knuckles or barbs on top of a chain link fence. Second, it displays nicely as a decorative trim piece to complement any galvanized or colored chain link fence system.

Don't settle for competitive designs and styles that pose an installation challenge, do not blend with the natural contours of the top of the fence, or offer our impressive, long-term warranty.

 **DESIGN:** Durable and flexible plastic in an open tubular shape.

 **DURABILITY:** Manufactured using HDPE plastic with UV stabilizers. This product is designed to endure high impact, to resist the harmful effects of the sun, and to withstand severe weather conditions.

 **SECURITY:** Resists vandalism by using the hog-rings to permanently attach the Safety Top Cap to the fence.

 **INSTALLATION:** Simply "snap" over the top of the fence and lock to the wire mesh with steel hog-rings (included with each package) through the (3) three pre-drilled holes on each piece.

 **MULTIPLE USES:** Primarily used in our safety yellow color for baseball outfields. This product is also growing in popularity at athletic fields, parks, playgrounds and recreational facilities throughout the country.

Ask for details about the 25-year warranty.

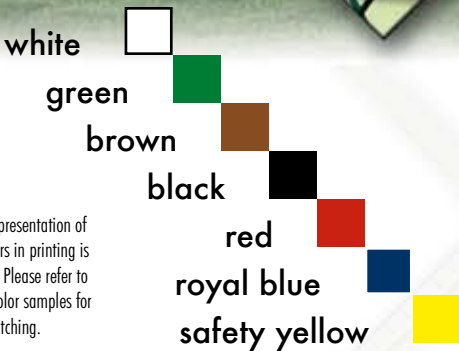

* Exact representation of slat colors in printing is difficult. Please refer to actual color samples for final matching.

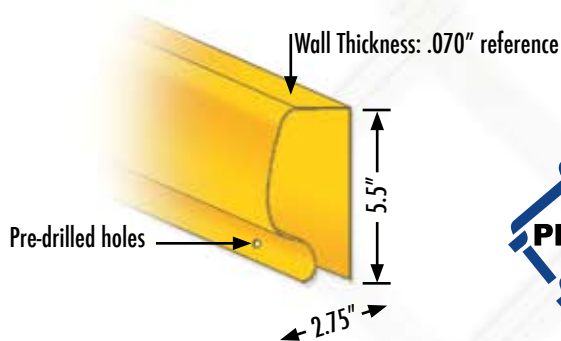

Filtrona Extrusion (East)
P.O. Box 370
Athol, MA 01331
1.800.755.7528

Filtrona Extrusion (West)
3110 70th Ave. E.
Tacoma, WA 98424
1.800.822.7528

www.pdsfence.com

patented products from  **FILTRONA** EXTRUSION

FENCE PRODUCTS SPECIFICATIONS

SAFETY TOP CAP SIZE SPECS

CAP HEIGHT	CAP WIDTH	CAP LENGTH	CAPS PER BAG	APPROX. COVERAGE PER BAG	HOT RINGS PER BAG
5 1/2"	2 3/4"	8'	5	40 LINEAR FEET	15

MATERIALS

The Safety Top Cap product is extruded from High Density Polyethylene (HDPE), color pigments and ultra violet (UV) inhibitors, specifically designed to retard the harmful effects of the sun and lengthen the life of the product.

DURABILITY

PDS® HDPE Fence Products are resistant to: severe weather conditions, salt water, sand, road dirt, most acids, alcohol, alkaline, ammonia, petroleum distillates, and common environmental pollutants.

MAINTENANCE

Pressure cleaning of surface contaminants is quickly accomplished with plain water.

INSTALLATION

Simply "snap" over the top of the fence and lock to the wire mesh with steel hog-rings (included with each package) through the (3) three pre-drilled holes on each piece.

LIMITED WARRANTY

Safety Top Cap carries a 25-year, pro-rata warranty against breakage under normal conditions. Write Filtrona Extrusion for full warranty information.

HDPE TECHNICAL PROPERTIES

Property	Value
Melt Index	(.6) A low melt index indicates improved stress and crack resistance.
Density	(.957) Polyethylene ranges anywhere from .914 to .960 in density. A higher density yields maximum stiffness without becoming overly brittle.
Minimum Temp.	(-76° F) Polyethylene stays flexible even at this temperature extreme.
Maximum Temp.	(250° F) Polyethylene does not distort until reaching this temperature.
Tensile Strength	(3,700 psi) Material will not suffer distortion at lesser loads or impacts.

Contact your local fence professional for more information about our complete line of enhancement products.

